

### 3.15 Booklets

#### 3.15.1 Definition

[9-8-09] Booklets must have a bound edge. Sheets that are fastened with at least two staples in the manufacturing fold (saddle stitched), perfect bound, pressed-glued, or joined together by another binding method that produces an end where pages are attached together are considered booklets. Booklets are open on three sides before sealing, similar in design to a book. In general, booklets must be uniformly thick. Large bound booklets that are folded for mailing qualify for automation and machinable prices if the final mailpiece remains nearly uniform in thickness.

#### 3.15.2 Paper

[9-8-09] Booklet covers generally must be made with a minimum paper basis weight of 60-pounds or equivalent. Minimum basis weights are higher for some designs (see 3.15.4).

#### 3.15.3 Physical Standards for Booklets

[9-8-09] Booklets must be:

- Height: not more than 6 inches or less than 3.5 inches high.
- Length: not more than 10.5 inches or less than 5 inches long. See [Exhibit 3.15.4](#) for some booklet designs with shorter maximum lengths.
- Thickness: not more than 0.25 inch or less than 0.009 inch thick.
- Weight: not more than 3 ounces.
- Aspect ratio: within 1.3 to 2.5 (see 3.1).

#### 3.15.4 Booklet Design and Sealing

[10-5-09] [9-8-09] The position of the final fold and intermediate fold (or spine) for letter-sized booklets varies according to the specific design of the mailpiece. Open edges can be sealed with tabs, glue lines, or glue spots. Except for the simple spine wallet-style design with a height of 4 inches and a maximum length of 8 inches; tabs used as seals on the leading edge of small booklets less than 5 inches high, may be placed closer to the top and bottom edges than shown in [Exhibit 3.15.4](#) and may overlap in some cases. See [Exhibit 3.15.4](#) for design and sealing standards.

#### Exhibit 3.15.4 Booklet Design

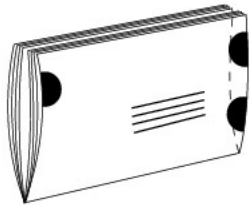
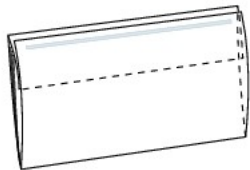
	If The Spine Or Final Fold Is...	Length	Cover Stock	Sealing	Tab In These Locations
Simple Spine 	Spine or final fold on the bottom (longer) edge.	5" to 9" long Over 9", up to 10.5" long	50-pound 60-pound	Three 1.5" non-perforated tabs	Two tabs on leading edge; one tab on trailing edge. Position lower leading tab 0.5 inch from the bottom edge. Position upper tabs within 1 inch from the top edge.
Simple Spine 	Spine on bottom; longer front cover folded over inside pages to create a nonperforated inner flap sealed within top edge.	5" to 9.5" long	80-pound	Continuous glue line or glue spots	Perfect bound or saddle stitched, flap sealed inside, continuous glue line along flap preferred, minimum 1 inch glue spots

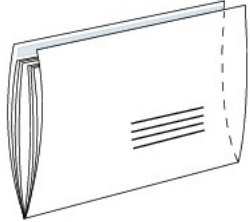
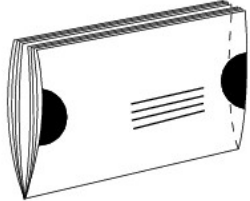
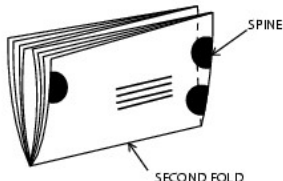
						acceptable if placed within 3/4 inch of right and left edges.
Simple Spine		Spine on the bottom (longer) edge, Cover extends no more than 1/2 inch beyond inner pages.	5" to 9.5" long	80-pound	Continuous glue line or glue spots	Perfect bound or saddle stitched with a continuous glue line along the 1/2 inch cover overhang preferred, minimum 1 inch glue spots acceptable if placed within 3/4 inch of right and left edges.
Simple Spine - Wallet Style		Saddle-stitched spine (two or more staples) on the bottom (longer) edge. 4" height only. Maximum Weight 2.5 ounces.	5.2" to 8" long	60-pound for cover and pages 70-pound cover with 50-pound pages	Two 1.5" or 2" non-perforated tabs	One tab on leading edge and one tab on trailing edge. Booklets up to 2 ounces: <ul style="list-style-type: none"> <li>• 1.5" tabs</li> <li>• 1-1/4" from bottom edge</li> </ul> Over 2 ounces up to 2.5 ounces: <ul style="list-style-type: none"> <li>• 2" tabs</li> <li>• 3/4" from bottom edge</li> </ul> ±1/8" vertical tolerance for tab placement for both tab sizes.
Folded		Final fold on the bottom (longer) edge, with the folded spine on the leading or trailing (shorter) edge.	5" to 10.5" long	40-pound	Three 1.5" non-perforated tabs	Two tabs on leading edge; one tab on trailing edge. Position lower leading tab 0.5 inch from the bottom edge. Position upper tabs within 1 inch

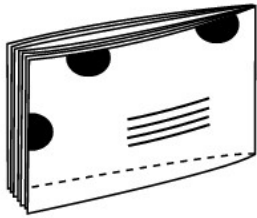
Oblong		Spine on the leading (shorter) edge.	5" to 9" long Over 9", up to 10.5" long	60-pound 70-pound	Three 1.5" non-perforated tabs	from the top edge. Two tabs on top edge; one tab on trailing edge. Position top tabs 1 inch from left and right edge. Position trailing tab in the middle.
--------	---	--------------------------------------	--	----------------------	--------------------------------	---